

## SHV - STRAIGHT CABLE PLUG & SEALED BULKHEAD RECEPTACLE 5kV<sub>DC</sub> / 3.5kV<sub>RMS</sub>

### FEATURES

- Rated Voltage 5kV<sub>DC</sub> / 3.5kV<sub>RMS</sub>
- Rated Current 500mA
- Completed cable assemblies available
- RoHS compliant

### APPLICATIONS

- Safe high voltage laboratory wiring
- High voltage power supplies / amplifiers
- Nuclear instrumentation
- Test and measurement equipment

SHV (Safe High Voltage – Nuclear Instrumentation Module Standard) reverse polarity, coaxial high voltage connectors. The straight cable plug 57K101-106N3 is compatible with standard RG58-C/U or our 20kV rated LSZH **HRG58-20-2** coaxial cable for crimp assembly. For high temperature applications it can also be assembled with silicone insulated coaxial cable **HSL-8S-0.75-B-2**. A suitable crimping tool is available on request. The outer ground connection is maintained during unintended mating/unmating. The center contacts are recessed to prevent shock hazard when the connectors are mated. For personal safety the connectors should not be mated or unmated when energized! The connectors are RoHS compliant.

Remark: SHV and BNC connectors are not intermateable.

### SPECIFICATIONS

Impedance:	50Ω
Frequency:	DC to 300MHz
Insulation resistance:	≥ 1000GΩ
Center contact resistance:	≤ 2mΩ
Outer contact resistance:	≤ 1.5mΩ
Operating voltage:	max. 5000V <sub>DC</sub> / 3500V <sub>RMS</sub>
Test voltage:	min. 10000V <sub>DC</sub> / 5000V <sub>RMS</sub> (at sea level)
Operating current:	500mA (average) / 10A (peak)
Mating cycles:	min. 500
Coupling nut retention:	≥ 450N (jack)
Center contact captivation:	≥ 18N (axial) / ≥ 3Ncm (radial)
Operating temperature:	-55 to +155°C
Weight straight cable plug:	20.4g
bulkhead receptacle:	11.0g

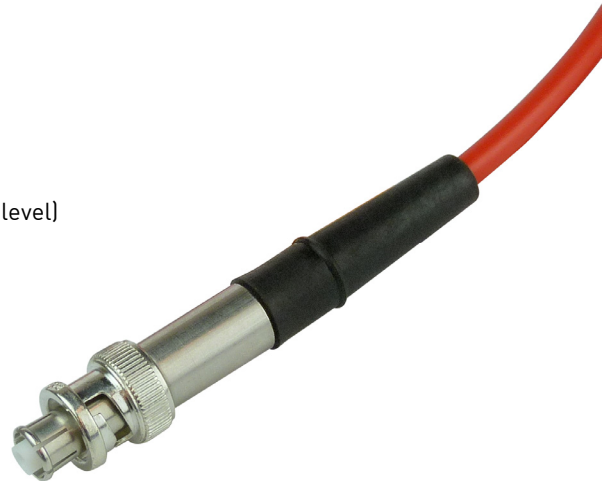

### Material and plating

Connector part	Straight Cable Plug 57K101-106N3		Bulkhead Receptacle 57S501-200N3	
	Material	Plating	Material	Plating
Center contact	Beryllium copper	Gold, min. 1.27 μm, over nickel	Brass	Gold, min. 1.27 μm, over nickel
Outer contact	Beryllium copper	Flash white bronze over silver	Brass	White bronze
Body	Brass	Flash white bronze over silver	Brass	Flash white bronze over silver
Dielectric	PTFE	-	PTFE	-
Gasket	Silicone	-	NBR	-

## DIMENSIONS

- STRAIGHT CABLE PLUG 57K101-106N3

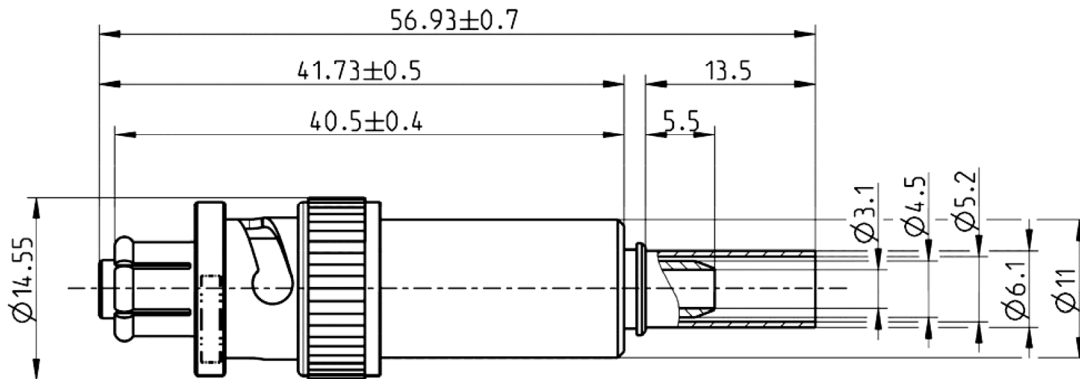

- BULKHEAD RECEPTACLE 57S501-200N3

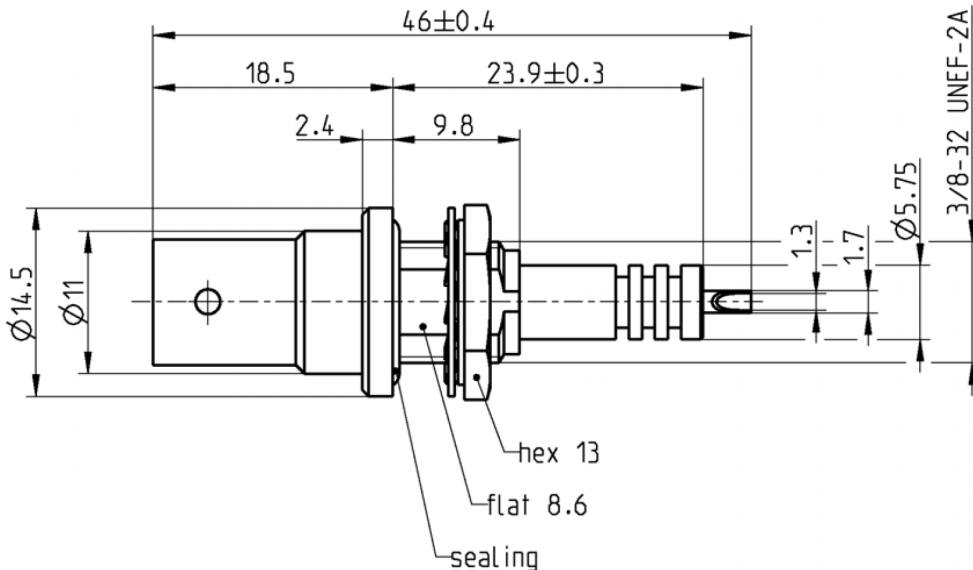

Dimensions are in mm. Drawings not to scale.

## ORDERING INFORMATION

- |                                  |                     |
|----------------------------------|---------------------|
| SHV Straight Cable Plug (female) | <b>57K101-106N3</b> |
| SHV Bulkhead Receptacle (male)   | <b>57S501-200N3</b> |

The SHV plug can be assembled by the user (see next chapter for assembly instructions).

Bespoke ready-to-use high voltage cable assemblies based on several high voltage cable types are available. The cable assemblies are fully tested.

Please contact [hivolt.de](http://hivolt.de) for details.

Examples:

Cable: HRG58-20-2; Length: 2m; SHV plug assembled on both sides

**HCA-005-S01-002-S01-A**

Cable: HSL-8S-0.75-B-2; Length: 80m; SHV plug assembled on one side

**HCA-005-S01-080-B**

## ACCESSORIES

- |                            |                    |
|----------------------------|--------------------|
| Bend Relief for Cable Plug | <b>1Z526-006SW</b> |
|----------------------------|--------------------|

## ASSEMBLY INSTRUCTIONS – CABLE PLUG

1.

Components of the connector:

- A: ferrule
- B: center pin
- C: connector body

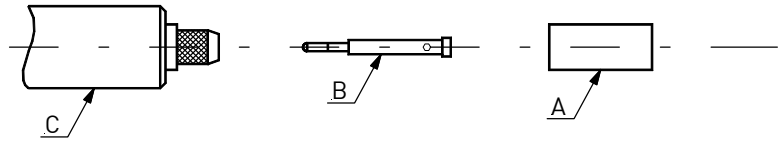

2.

- If a bend relief should be used, slide it onto the cable (recommended).
- Slide ferrule A onto the cable.
- Remove cable jacket according to the diagram

⚠ Do not damage the shield wires!

- Shorten the braid and remove the dielectric insulation according to the diagram (dimensions in mm).

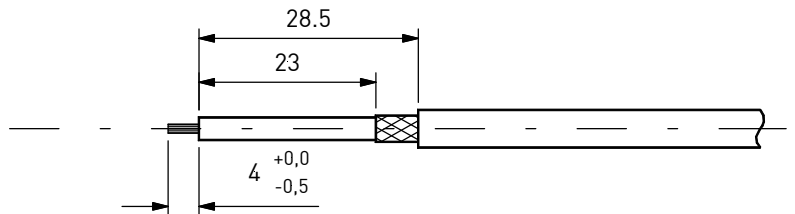

⚠ Do not damage the dielectric insulation!

- Carefully remove loose shield wires completely. Loose shield wires can cause electrical breakdown.

3.

- Push center pin B over the inner conductor of the cable up to the dielectric and crimp or solder.
- Splay out the braid.

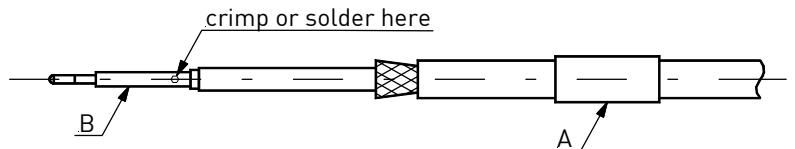

4.

- Insert the prepared cable into the connector body C until the center pin engages perceptibly. Ensure that the braid covers the knurled connector end.
- Slide ferrule A over the braid up to the connector body and crimp as close to the connector body as possible.
- If present, slide the bend relief over the ferrule and push it firmly against the connector body.

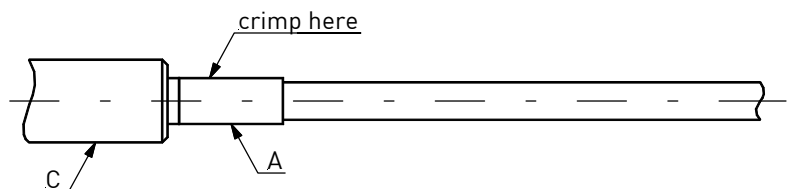

⚠ Important notes:

1. Carefully read assembly instructions before starting the assembly process.
2. Cable assembly must only be done by trained and qualified personnel.
3. Insulation and conduction properties of the completed cable assembly must be tested prior to operation.

### Disclaimer

The information given in this data sheet is technical data, not assured product characteristics. It has been carefully checked and is believed to be accurate; however, no responsibility is assumed for inaccuracies. The user has to ensure by adequate tests that the product is suitable for his application regarding safety and technical aspects. hivolt.de GmbH & Co. KG does not assume any liability arising out of the application or use of any product described.

### Safety Advice

Design, installation and inspection of machinery and devices carrying high voltage require accordingly trained and qualified personnel. Appropriate safety rules and directives must be complied with. Improper handling of high voltage can mean severe injuries or death and may cause serious collateral damage!